

# V3

The V3 serie comprises 2 models of actuators ;  
 -the Master actuator integrating a transformer 220/24 V and a printed circuit board for the control,  
 -the Slave actuator supplied with 24 VDC and controlled by a Master actuator or by any other control box.  
 The Master V3 can operate alone and/or control 1, 2 or 3 Slave actuators (V3 or V8).  
 These actuators are compact and elegant with small dimensions to facilitate the installation on the application.

Mains power supply of Master actuator	230 VAC 50-60 Hz
Motor type V3M	Motor 24 VDC
Motor type V3E	Motor 12 VDC or 24 VDC
Push force	3000 N maxi
Pull force	3000 N maxi
Duty cycle	2 mn operation / 18mn stand-by (10%)
Operating temperatures	+5° to +40°
Protection grade	IPX4
Colour	Light Grey (RAL 7035) or Black (RAL 7021)

#### Options :

Mains power supply of Master actuator	110 VAC 50-60 Hz
Electrical safety	Power cut-off plug (Master actuator)
Reset function without Mains power supply	With batteries
Mounting fork positioning	0° or 90°
Mounting fork material	Plastic or metallic
Material of thrust tube	Stainless steel
Protection grade	IP56
Intermediate stroke	3rd micro-switch
Mechanical safety	Push Only
Memory/synchronisation function	With hall effect sensor

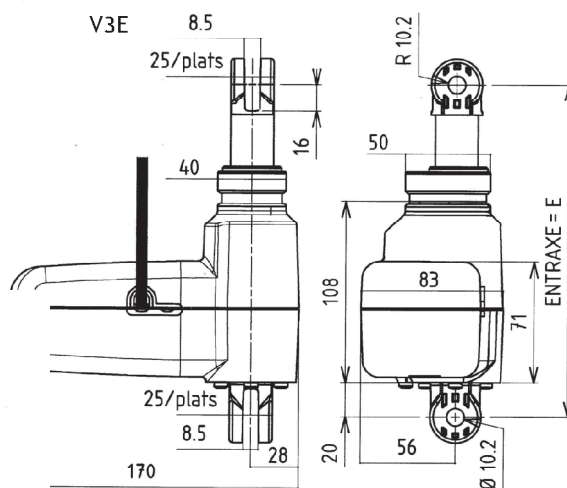
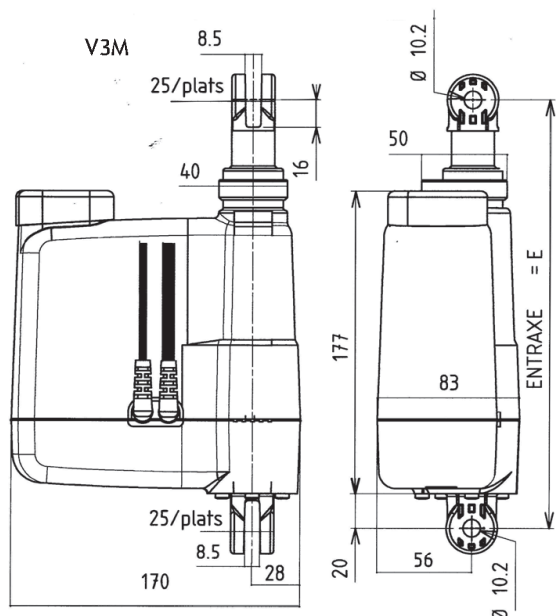

Stroke / retracted length upon request

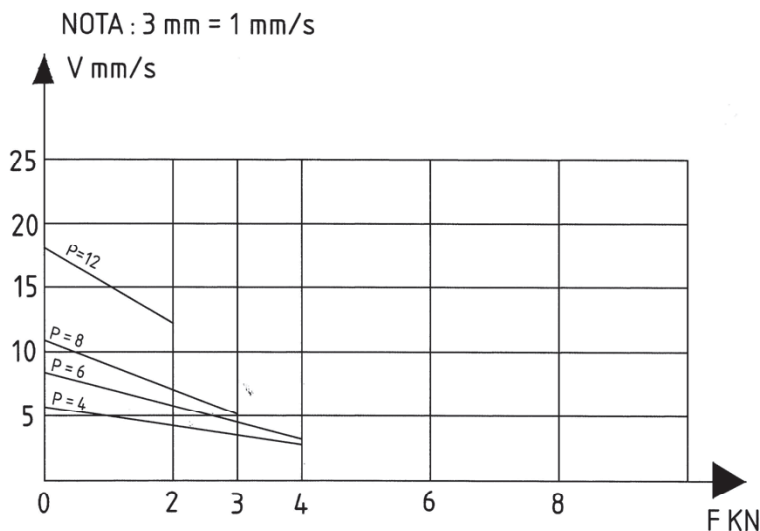

LINEAR ACTUATORS